



techhose

QUALITY CONNECTIONS

Hydraulics

Pneumatics
& Vacuum

Industrial

Compressed Air
& Ring Main

Process &
Instrumentation

Pneumatic & Vacuum

Air Boosters

PRESSURE BOOSTERS

Air Pressure Booster

The air-to-air pressure multiplier, or booster, is an automatic device that compresses air to give an outlet pressure that is double the inlet pressure. It is normally used to locally intensify the input pressure of one or more actuators. As it is entirely pneumatic it can be used when electric devices are not recommended. The booster can be supplied with or without a pressure regulator.

It is fitted with check valves that maintain the outlet pressure even when the supply of compressed air is switched off. This means it is necessary to interrupt the supply and relieve the circuit before intervening on the device in any way. It is advisable to install a tank after the booster to prevent fluctuations in outlet pressure.

Technical Data

		Booster Ø40	Booster Ø40 with regulator	Booster Ø63	Booster Ø63 with regulator
Bore		Ø 40		Ø 63	
Fluid		Filtered unlubricated compressed air. Lubrication, if used, must be continuous.			
Threaded port		G1/8		G3/8	
Inlet pressure	MPa	0.2-1			
	bar	2-10			
	psi	29-145			
Outlet pressure	MPa	Maximum 2	Maximum 1.6 (regulated)	Maximum 2	Maximum 1.6 (regulated)
	bar	Maximum 20	Maximum 16 (regulated)	Maximum 20	Maximum 16 (regulated)
	psi	Maximum 290	Maximum 232 (regulated)	Maximum 290	Maximum 232 (regulated)
Operating temperature	°C	-10° to +60°		-10° to +60°	
	°F	+14° to +140°		+14° to +140°	
Weight	gr	1.380	1.600	4.240	5.350
Mounting		Wall or panel			
Installation		In any position			

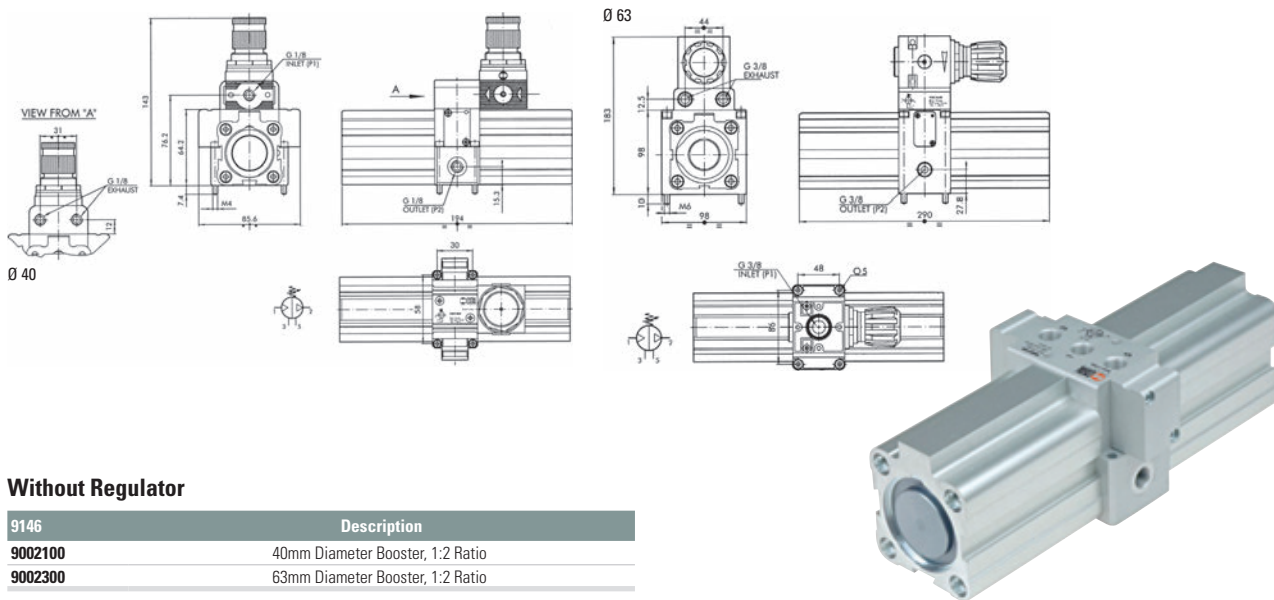

Without Regulator

Code	Description
9146	
9002100	40mm Diameter Booster, 1:2 Ratio
9002300	63mm Diameter Booster, 1:2 Ratio

Air Regulators

To suit Air Pressure Multiplier (Booster)

Code	Description
9193	
9002180	40mm Regulator Unit
9002380	63mm Regulator Unit

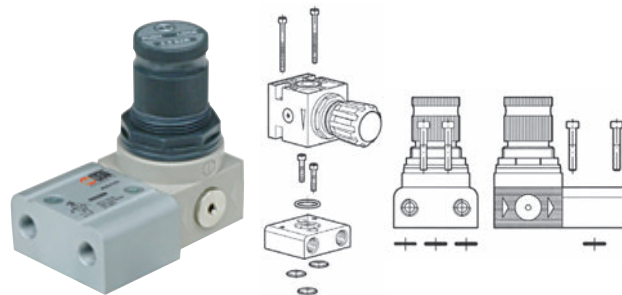

PRESSURE BOOSTERS

Pressure Boosters



40mm complete with Regulator, BSPP

0110	Thread
1740.50.NR	1/8"



63mm complete with Regulator, BSPP

0110	Thread
1763.80.NR	3/8"



100mm complete with Regulator, BSPP

0110	Thread
17100.125.NR	1/2"



P+ Pressure Booster 40mm 0-20 bar complete with Gauges

0110	Thread
MDPT40.2R.A	1/4"



P+ Pressure Booster Mounting Bracket

0110	Description
T1740.01	Mounting for P+ 40mm Booster



Mounting Bracket 40/63/100mm

0110	To Suit
1740.02	40mm
1763.03	63mm
17100.04	100mm